

**INSTALLED BOOT
ISOMETRIC VIEW**

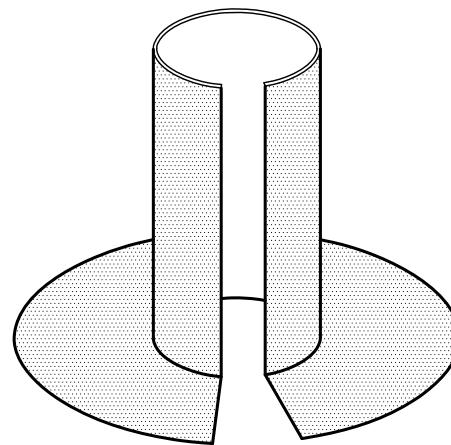

**UNINSTALLED BOOT
ISOMETRIC VIEW**

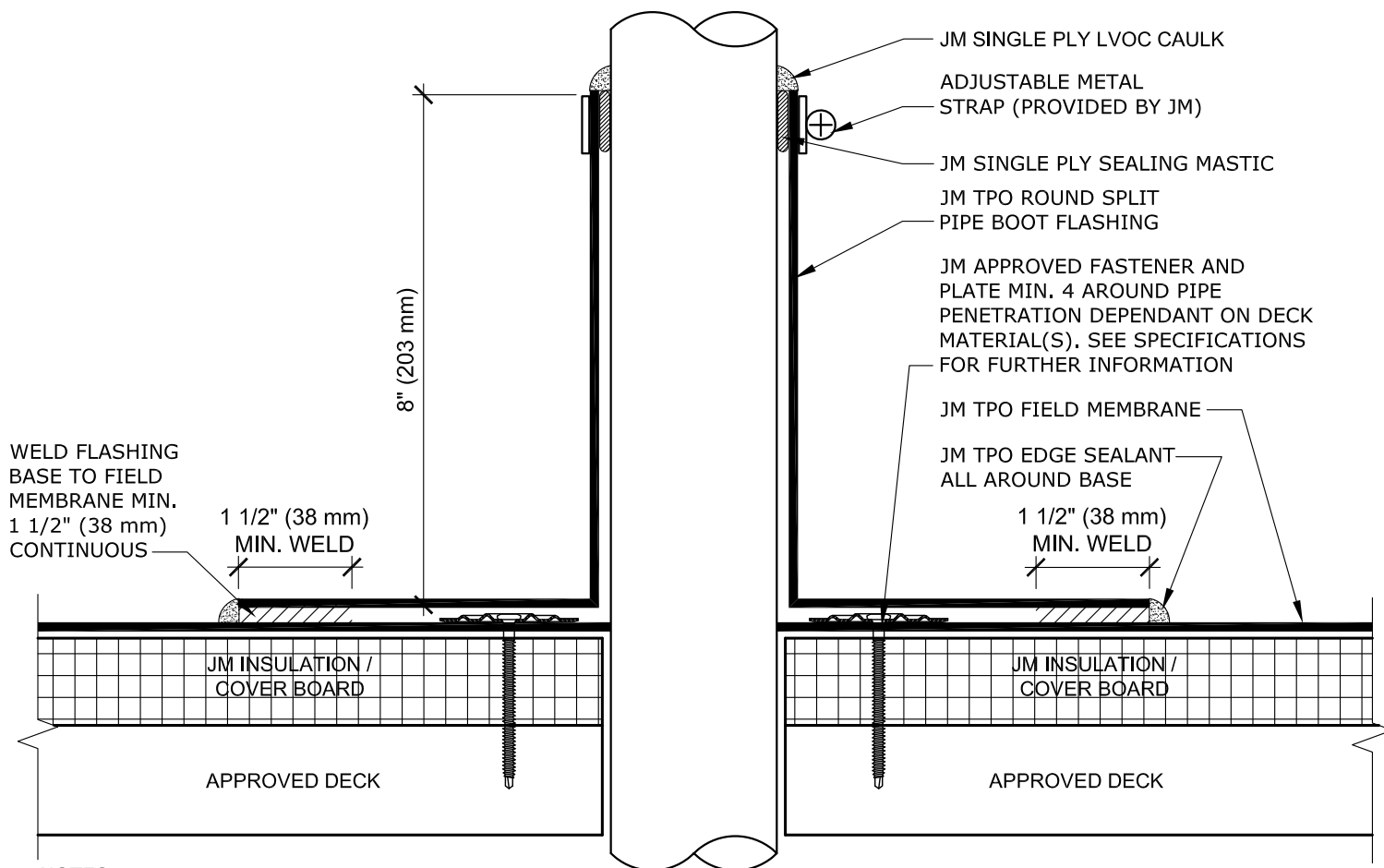

NOTES:

1. REFER TO JOHNS MANVILLE WEBSITE (www.jm.com) FOR MOST UP-TO-DATE INFORMATION.
2. ANY CARPENTRY OR METAL WORK SHOULD BE DESIGNED AND CONSTRUCTED IN ACCORDANCE WITH LOCAL CODE REQUIREMENTS AND/OR PROJECT SPECIFICATIONS. THESE COMPONENTS SHOULD BE REVIEWED AND APPROVED BY A LICENSED DESIGN PROFESSIONAL.
3. STANDARD JM ROUND SPLIT PIPE BOOT SIZES ARE 1", 2", 3", 4", 5" & 6".

DRAWING NO.

T-FP-04

TPO SPLIT PIPE BOOT (ROUND)

NEW DETAIL

MEMBRANE TYPE:
JM TPO

SCALE
N.T.S

ISSUE DATE
11-17-16

MAXIMUM GUARANTEE TERM:
20 YEAR

Johns Manville is a manufacturer of commercial roofing products and offers this general conceptual information to you as a courtesy. This complimentary assistance is not to be used or relied upon by anyone as a substitute for professional engineering design and documentation required by building code, contract, or applicable law. By accepting these comments you agree they do not constitute any representations, endorsements of, or an assumption by Johns Manville of any liability for either the adequacy of the design of this building or any other material not supplied by Johns Manville.

