

JM APPROVED FASTENER & PLATE - INSTALL 2 AROUND PENETRATION AS SHOWN. PLATES MUST NOT BE LOCATED UNDER THE WELDED FLANGE. INSTALL A TARGET PATCH IF PLATES CONTACT THE WELDED FLANGE.

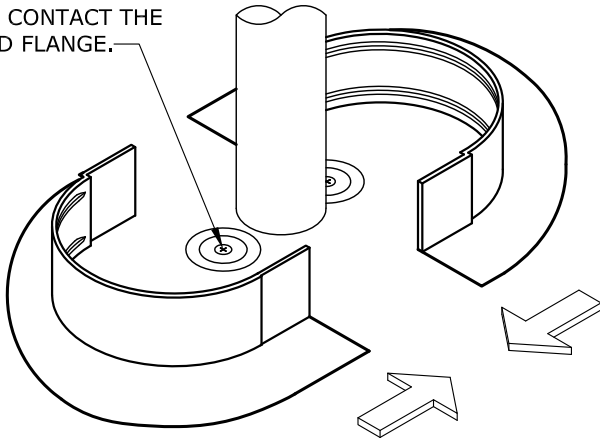

JM TPO 2 PIECE PENETRATION POCKET

THE JM TPO PENETRATION POCKET IS A TWO-PIECE MOLDED POCKET WITH A RIGID VERTICAL WALL AND PRE-FORMED FLANGE AS SHOWN

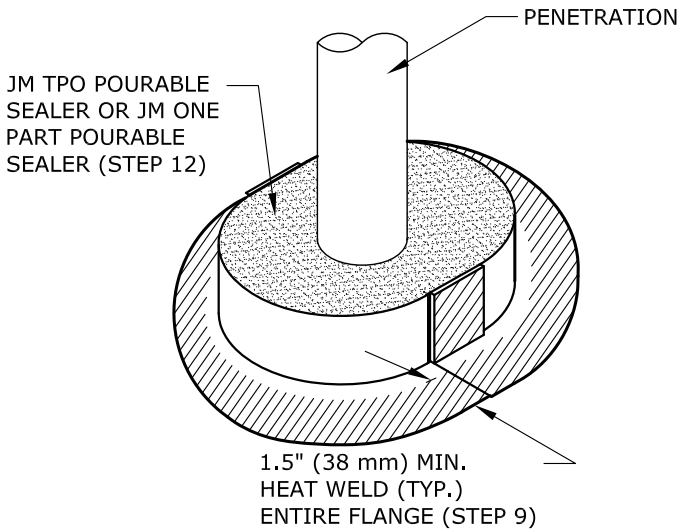
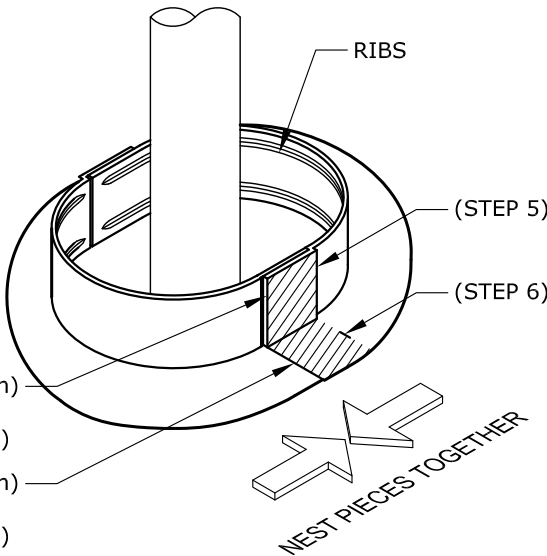

INSTALLATION STEPS:

1. USING A WIRE BRUSH OR GRINDER, CLEAN PENETRATION DOWN TO BARE METAL FROM JUST BELOW THE MEMBRANE SURFACE TO JUST ABOVE THE TOP OF THE TPO PENETRATION PAN COLLAR TO ALLOW GOOD ADHESION BETWEEN THE PENETRATION AND THE JM TPO POURABLE SEALER.
2. USING JM TPO MEMBRANE CLEANER, CLEAN THE INSIDE OF THE JM TPO PENETRATION POCKET. ALSO, CLEAN AREAS WHERE THE POCKET OVERLAPS THE UNDERSIDE OF THE POCKET FLANGE AND MEMBRANE.
3. PLACE THE JM TPO PENETRATION POCKET AROUND THE PENETRATION, NESTING THE TWO SECTIONS OF THE POCKET TOGETHER.
4. USING A 4" x 4" PIECE OF THICK CARDBOARD AS A HEAT SEPARATION SHEET, PLACE CARDBOARD UNDER OVERLAP SECTION OF PENETRATION PAN.
5. USING A HANDWELDER, WELD THE 2 PIECE "VERTICAL" COLLAR TOGETHER FROM THE 90 DEGREE VERTICAL / HORIZONTAL ANGLE CHANGE, TO THE TOP OF THE VERTICAL TPO COLLAR, BEING CAREFUL TO AVOID COLD WELDS AND VOIDS. (POSITION THE POCKET SO THE VERTICAL LAP IS AGAINST THE PENETRATION. THIS ALLOWS PROPER PRESSURE TO BE APPLIED TO THE OVERLAP WITH A 2" SILICONE ROLLER.)
6. USING A HANDWELDER, WELD THE 2 PIECE "HORIZONTAL" COLLAR TOGETHER FROM THE 90 DEGREE VERTICAL / HORIZONTAL ANGLE CHANGE, TO THE OUTSIDE EDGE OF THE HORIZONTAL TPO POCKET FLANGE, BEING CAREFUL TO AVOID COLD WELDS AND VOIDS. (POSITION THE POCKET SO THE HORIZONTAL LAP IS AGAINST THE CARDBOARD. THIS ALLOWS PROPER PRESSURE TO BE APPLIED TO THE OVERLAP WITH A 2" SILICONE ROLLER.)
7. REPEAT STEPS 5 AND 6 TO WELD THE OVERLAPS OF THE OPPOSITE SIDE OF THE PENETRATION PAN.
8. IF NECESSARY, TACK WELD THE PENETRATION POCKET IN PLACE AROUND THE PENETRATION, LEAVING A MINIMUM ONE INCH SPACE BETWEEN THE PENETRATION AND THE TPO PENETRATION COLLAR.
9. WELD THE ENTIRE HORIZONTAL FLANGE TO THE TPO FIELD MEMBRANE.
10. USING A SEAM PROBE, CHECK ALL LAPS FOR COLD WELDS AND VOIDS. MAKE ANY NECESSARY REPAIRS.
11. USING A SMALL PAINT BRUSH, APPLY A THIN COAT OF JM TPO MEMBRANE PRIMER OR JM SINGLE PLY MEMBRANE PRIMER (LOW VOC) TO THE INSIDE RIM AND AROUND THE THE TOP RIM OF THE POCKET. ALSO APPLY PRIMER TO THE MEMBRANE AREA ENCLOSED BY THE POCKET AND THE PENETRATION ITSELF.
12. FILL THE POCKET WITH JM TPO POURABLE SEALER OR JM ONE PART POURABLE SEALER. USE AN ADEQUATE AMOUNT OF SEALANT TO ENSURE PROPER CONTACT IS MADE WITH THE TOP RIM OF THE POCKET.
13. POURABLE SEALER IS A SEALANT TO BE MAINTAINED BY THE OWNER.

DRAWING NO.

T-FP-02

REPLACES TF-53

SCALE N.T.S. ISSUE DATE 1-12-17

JM TPO 2 PIECE PENETRATION POCKET

MEMBRANE TYPE:
JM TPO

MAXIMUM GUARANTEE TERM:
20 YEAR

Johns Manville is a manufacturer of commercial roofing products and offers this general conceptual information to you as a courtesy. This complimentary assistance is not to be used or relied upon by anyone as a substitute for professional engineering design and documentation required by building code, contract, or applicable law. By accepting these comments you agree they do not constitute any representations, endorsements of, or an assumption by Johns Manville of any liability for either the adequacy of the design of this building or any other material not supplied by Johns Manville.

