

JM PMMA MEMBRANE
TARGET PATCH OVER SCUPPER OPENING

PREPARE, LEVEL & PATCH SUBSTRATE WITH
JM PMMA REPAIR PASTE AFTER
PRIMING & PRIOR TO INSTALLATION
OF JM PMMA MEMBRANE

JM PMMA MEMBRANE
2" MIN. OVERLAP PROVIDING
CONTINUOUS FLASHING

JM PMMA MEMBRANE FLASHING
EXTENDED THROUGH TO THE OUTSIDE OF
SCUPPER OPENING AND OVERLAP 2" TO
FORM SCUPPER FLASHING

ENSURE FULL RESIN SATURATION
OF JM PMMA SCRIM
AND CONTACT WITH SUBSTRATE

ENSURE ALL MEMBRANE TERMINATIONS ARE
ENCAPSULATED IN JM PMMA RESIN

JM PMMA FIELD MEMBRANE

THOROUGHLY CLEAN METAL SCUPPER
SLEEVE AND APPLY JM PMMA
METAL PRIMER PRIOR TO INSTALLATION OF
JM PMMA MEMBRANE FLASHING

SCUPPER SIZED BY LICENSED
DESIGN PROFESSIONAL
RE: NOTE 3

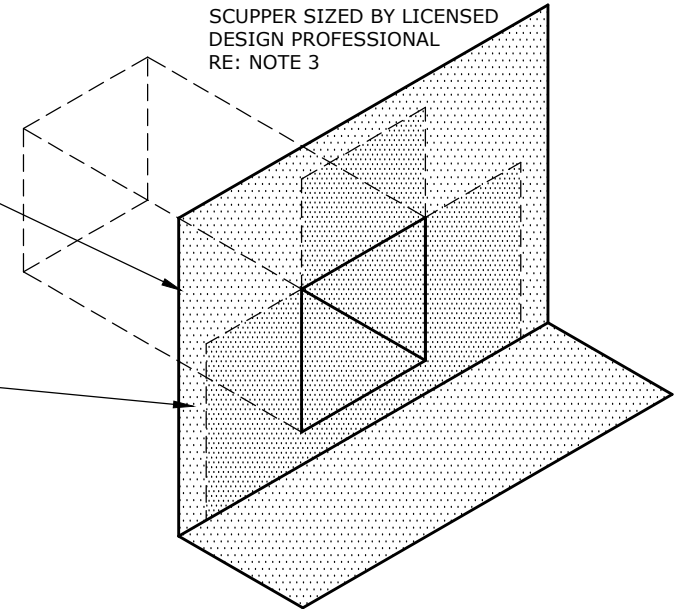

ISOMETRIC VIEW

USE THIS DETAIL IN CONJUNCTION WITH DETAIL
L-DV-03S WHICH IS PART OF THIS INSTALLATION.

NOTES:

1. REFER TO JOHNS MANVILLE WEBSITE (www.jm.com) FOR MOST UP-TO-DATE INFORMATION.
2. PLEASE SEE JM PMMA FLASHING SPECIFICATIONS FOR A FULL DESCRIPTION OF INSTALLATION INSTRUCTIONS AND REQUIREMENTS WHICH ARE CONSIDERED A PART OF THIS DETAIL.
3. ANY CARPENTRY OR METAL WORK SHOULD BE DESIGNED AND CONSTRUCTED IN ACCORDANCE WITH LOCAL CODE REQUIREMENTS AND/OR PROJECT SPECIFICATIONS. THESE COMPONENTS SHOULD BE REVIEWED AND APPROVED BY A LICENSED DESIGN PROFESSIONAL.
4. JM PMMA MEMBRANE FLASHING CONSISTS OF JM PMMA FLASHING RESIN, JM PMMA SCRIM, JM PMMA FLASHING RESIN. USE THE APPROPRIATE JM PMMA PRIMER DEPENDING ON TYPE OF SUBSTRATE.
5. ALL SEALANTS / CAULKING SHALL BE PERIODICALLY INSPECTED AND MAINTAINED BY THE BUILDING OWNER THROUGHOUT THE LIFE OF THE ROOF.

JM PMMA THROUGHWALL OVERFLOW SCUPPER FLASHING

DRAWING NO.
L-DV-03
DRAINS & VENTS

MEMBRANE TYPE:
JM PMMA
MAXIMUM GUARANTEE TERM:
20 YEAR

ISSUE DATE
09-11-24
SCALE
N.T.S

Johns Manville is a manufacturer of commercial roofing products and offers this general conceptual information to you as a courtesy for general educational purposes only. This complimentary assistance is not to be either used or relied upon by anyone as a substitute for professional engineering design and documentation required by any building code, contract, or applicable law. By accepting the general conceptual information, you agree it does not constitute any representations, endorsements of, or an assumption by Johns Manville of any duty or liability for either the adequacy of the design of a building, any of its components or the sufficiency of any construction.

