

**NOTES**

1. CALCULATE UPLIFT DESIGN PRESSURES IN ACCORDANCE WITH ASCE 7-10.
2. FASTENING DIAGRAM IS BASED ON FM GLOBAL DATA SHEET 1-29.
3. INSTALL INSULATION WITH LONG JOINTS IN A CONTINUOUS STRAIGHT LINE WITH END JOINTS STAGGERED.
4. PERIMETER AND CORNER DIMENSIONS FOR BUILDINGS LESS THAN 60 ft. IN HEIGHT:  
EQUAL TO THE SMALLER OF:
  - 0.1 TIMES THE BUILDING LESSER PLAN DIMENSION (OVERALL LENGTH AND WIDTH)
  - 0.4 TIMES THE EAVE HEIGHT
  - BUT WILL NEVER MEASURE LESS THAN 0.04 TIMES THE BUILDING LESSER PLAN DIMENSION AND NEVER LESS THAN 3 ft.
5. PERIMETER AND CORNER DIMENSIONS FOR BUILDINGS GREATER THAN 60 ft. IN HEIGHT:
  - EQUAL TO 0.1 TIMES THE BUILDING LESSER PLAN DIMENSION (OVERALL LENGTH AND WIDTH), BUT NEVER LESS THAN 3 ft.
  - CORNERS ARE "L" SHAPED WITH LEGS TWICE THE WIDTH OF THE PERIMETER
6. THE CORNERS MAY BE TREATED AS PERIMETERS IF THE PARAPET IS GREATER THAN OR EQUAL TO 3 FT ON ALL SIDES ACCORDING TO ASCE 7-10.

**INSULATION FASTENING**

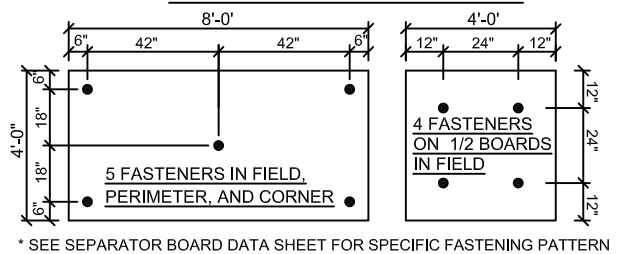

**CORNER DEFINITION**

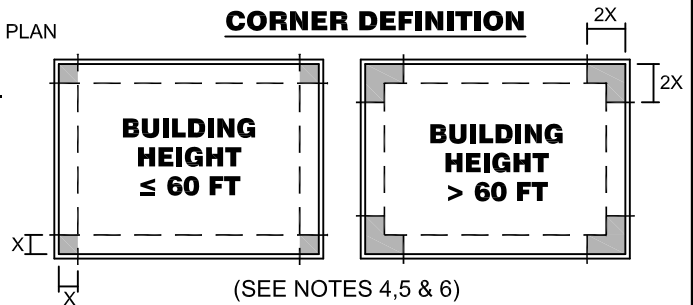

DRAWING NO.

**TM-6-RPS-PF**

MBR FASTENING

SCALE  
N.T.S

ISSUE DATE  
02-08-23

**TPO MECHANICALLY ATTACHED PICTURE FRAME 6 INCH OC WITH RPS**

MEMBRANE TYPE:  
TPO

MAXIMUM GUARANTEE TERM:  
30 YEAR

Johns Manville is a manufacturer of commercial roofing products and offers this general conceptual information to you as a courtesy for general educational purposes only. This complimentary assistance is not to be either used or relied upon by anyone as a substitute for professional engineering design and documentation required by any building code, contract, or applicable law. By accepting the general conceptual information, you agree it does not constitute any representations, endorsements of, or an assumption by Johns Manville of any duty or liability for either the adequacy of the design of a building, any of its components or the sufficiency of any construction.

