

Features and Components

The UltraFast Fastener is a #12, case-hardened steel, polymer-coated fastener with a butress thread design that provides maximum pullout values and minimizes fastener backout. Available with either a #3 Phillips head or a ¼" (6.35 mm) hex head. The drill point is designed for quick installation in new or re-roof applications, and provides exceptional drilling capability in higher tensile decks.

- Use:** Insulation
- Material:** Fasteners - Case-Hardened Steel, Polymer-Coated
- Gauge:** #12
- Head:** #3 Phillips Head or ¼" (6.35 mm) Hex Head
- Color:** Blue
- Deck Types:** Wood or 18 - 24 gauge (1.25 mm - 0.51 mm) Metal

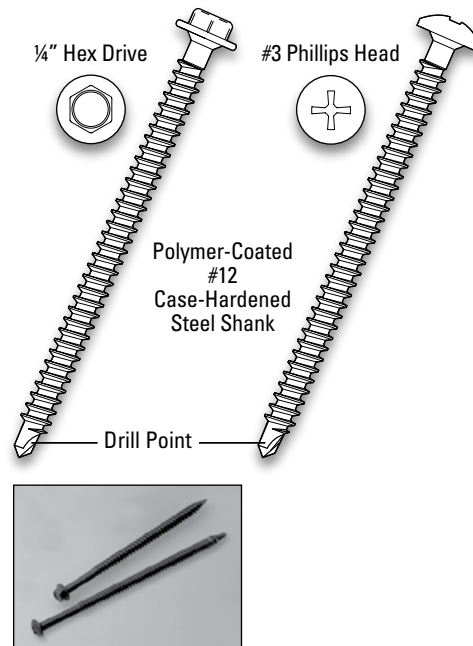

Component
F
 Fastening

Type
I
 Insulation

Multi-Ply
 Single Ply

System Compatibility *This product may be used as a component in the following systems. Please reference product application for specific installation methods and information.*

Multi-Ply	BUR		APP		SBS				
	HA	CA	CA	HW	HA	CA	HW	CA	MF
<i>Use to fasten Insulation in all Multi-Ply systems</i>									

Single Ply	TPO		PVC		EPDM		
	MF	FA	MF	FA	MF	FA	BA
<i>Use to fasten Insulation in the selected Single Ply systems above</i>							

Key: HA = Hot Applied CA = Cold Applied HW = Heat Weldable SA = Self Adhered MF = Mechanically Fastened FA = Fully Adhered BA = Ballasted

Energy and the Environment

Recycled Content	This steel based product contains a minimum of 25% post consumer recycled materials by weight
------------------	---

Peak Advantage® Guarantee Information

Systems	Approved to use with any Peak Advantage Guarantee
---------	---

Codes and Approvals*



*Fastener approvals are based on system approvals

Installation/Application

Refer to the application instructions guidelines for proper utilization of this product.

Packaging and Dimensions

Fastener Sizes	Quantity/Container
1½" to 8" (4.13 cm to 20.32 cm) (1) #3 Phillips bit in each pail (1) ¼" (6.35 mm) hex head bit per 3 pails	1,000/pail
Producing Locations*	Agawam, MA and Itasca, IL

*The point of manufacture for fasteners and plates varies depending on the specific part. Call your local JM sales professional for assistance.