



Permacote® Linacoustic® R-300

Rigid Fiber Glass Plenum Liner Board

Description

Permacote Linacoustic R-300 is a rigid fiber glass board that meets or exceeds all ASTM C 1071 Type II duct liner requirements. The airstream surface and the long edges are coated with a tough, smooth, state-of-the-art acrylic polymer. R-300 offers exceptional durability and superior acoustical and thermal performance.

Uses

R-300 is specifically designed for use as an extended performance lining insulation for HVAC plenums and air distribution ductwork.

General Properties

Operating temperature (max.) - ASTM C 411	250°F (121°C)
Air velocity (max.) - ASTM C 1071	6000 fpm (30.5 m/sec)
Water repellency - INDA IST 80.6	≥6
Fungi resistance - ASTM C 1338	Does not breed or promote
Fungi resistance - ASTM G 21	No growth
Bacteria resistance - ASTM G 22	No growth

Standard Thicknesses and Packaging

Thickness		Width		Length	
in	mm	in	mm	in	mm
1	25	48	1219	96	2438
1½	38	48	1219	96	2438
2	51	48	1219	96	2438

Non-standard sizes up to 4" (102 mm) thickness and 120" (3.1 m) lengths available on special request.

Surface Burning Characteristics

Permacote Linacoustic R-300 meets the Surface Burning Characteristics and Limited Combustibility of the following standards:

Standard/Test Method

• ASTM E 84	Maximum Flame Spread Index	25
• UL 723		
• NFPA 255	Maximum Smoke Developed Index	50
• NFPA 90A and 90B		
• NFPA 259		
• CAN/ULC S102-M88		

UL labels supplied on packages when requested on order.

Specification Compliance

- ASTM C 1071, Type II
- ASHRAE 62
- SMACNA Application Standards for Duct Liners
- NAIMA Fibrous Glass Duct Liner Installation Standard
- NYC MEA 353-93-M
- State of Washington Building Services Department requirements for emissions of total volatile organic compounds (TVOC) and formaldehyde (CHOH) in accordance with ASTM D 5116
- Canada: CGSB 51.10-92

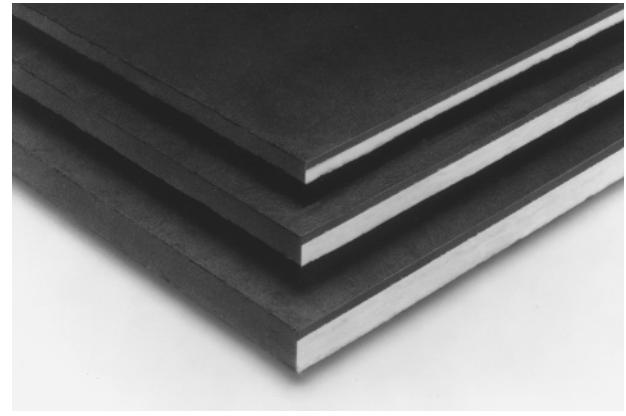

Advantages

Improves Indoor Building Environment. Permacote Linacoustic R-300 helps improve indoor environmental quality by helping to control both temperature and sound.

Absorbs Disturbing Sound. Permacote Linacoustic R-300 has exceptional sound-absorbing properties far exceeding the requirements of ASTM C 1071. Duct-transmitted noise, such as crosstalk and sound energy from air movement and mechanical equipment is noticeably reduced.

Resistant to Dust and Dirt. The tough, acrylic polymer Permacote coating helps guard against incursion of dust or dirt into the substrate, minimizing the potential for biological growth.

Will Not Support Microbial Growth. Permacote coating is formulated with an immobilized, EPA-registered, protective agent to protect the coating from potential growth of fungus and bacteria.

Permacote Linacoustic R-300 passes ASTM C 1071 fungi testing, as well as the more stringent ASTM G 21. Bacteria tests were conducted in accordance with ASTM G 22. Detailed information is available in Johns Manville fact sheet HSE-103FS.

Note: As with any type of surface, microbial growth may occur in accumulated duct system dirt, given certain conditions. This risk is minimized with proper design, filtration, maintenance and operation of the HVAC system.

Withstands High Velocity. Permacote Linacoustic R-300 has been tested to the recommended maximum velocity of 6,000 fpm (30.5 m/sec). Fiber erosion test results were determined using the Isokinetic Sampling Method described in Johns Manville Fiber Erosion Testing Fact Sheet HSE-133FS.

Cleanability. If necessary, the surface may be cleaned using standard industry-recognized dry methods. See the North American Insulation Manufacturers Association (NAIMA) "Cleaning Fibrous Glass Insulated Air Duct Systems."

Resists Damage. The specially designed Permacote airstream surface enhances the ability of R-300 to resist damage from typical in-shop handling, fabrication, and jobsite shipment.

Permacote® Linacoustic® R-300

Rigid Fiber Glass Plenum Liner Board

Installation

All portions of duct designated to receive duct liner shall be completely covered with Permacote Linacoustic R-300. The smooth, black Permacote surface of the Linacoustic R-300 shall face the airstream. All Permacote Linacoustic R-300 shall be cut to assure tight, overlapped corner joints. The top pieces shall be supported by the side pieces.

Permacote Linacoustic R-300 shall be adhered to the sheet metal with full coverage of an approved adhesive that meets ASTM C 916, and all exposed leading edges and transverse edges shall be coated with Johns Manville SuperSeal® Duct Butter, Johns Manville SuperSeal® Edge Treatment or an approved adhesive.

The Permacote Linacoustic R-300 shall be additionally secured with mechanical fasteners spaced per the schedule shown in the diagram below. The pin length should be such as to hold the material firmly in place with minimum compression of the material.

All material shall be installed in accordance with the NAIMA Fibrous Glass Duct Liner Installation Standard.

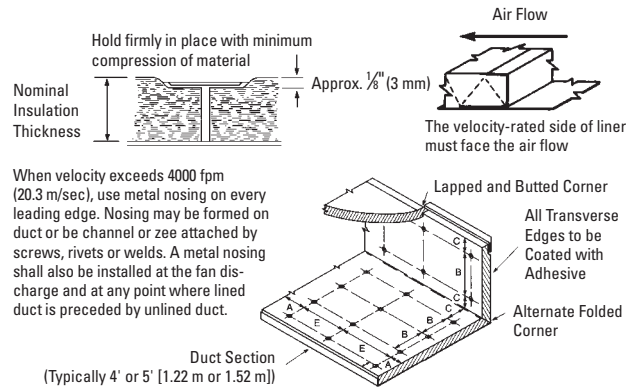

Maximum Spacing for Fasteners. Actual Intervals Are Approximate.

Velocity*	Dimensions			
	A in mm	B in mm	C in mm	E in mm
0 - 2500 fpm (0 - 12.7 m/sec)	3 76	12 305	4 102	18 457
2501 - 6000 fpm (12.7 - 30.5 m/sec)	3 76	6 152	4 102	16 406

*Unless a lower level is set by the listing agency.

Liner adhered to the duct with 90% minimum area coverage of adhesive. Adhesive shall conform to ASTM C 916.

Shop or field cuts shall be liberally coated with SuperSeal® Edge Treatment or approved adhesive.

Thermal Performance

Thickness in mm	R-Value		Conductance	
	(hr•ft ² •°F)/Btu	m ² •°C/W	Btu/(hr•ft ² •°F)	W/m ² •°C
1 25	4.3	0.76	0.23	1.31
1½ 38	6.3	1.11	0.16	0.91
2 51	8.7	1.53	0.12	0.68

R-value and Conductance are calculated from the material thermal conductivity tested in accordance with ASTM C 518 at 75°F (24°C) mean temperature.

Sound Absorption Coefficients (Type "A" Mounting)

Thickness in mm	Sound Absorption Coefficient at Frequency (Cycles per Second) of:						
	125	250	500	1000	2000	4000	NRC
1 25	0.04	0.26	0.69	1.00	1.07	1.02	0.75
1½ 38	0.14	0.52	1.01	1.07	1.03	0.97	0.90
2 51	0.26	0.73	1.10	1.10	1.04	1.03	1.00

Coefficients were tested in accordance with ASTM C 423 and ASTM E 795.

ISO 9000 Certification

Johns Manville mechanical insulation products are designed, manufactured and tested in our own facilities, which are certified and registered to stringent ISO 9000 (ANSI/ASQC 90) series quality standards. This certification, along with regular, independent third-party auditing for compliance, is your assurance that Johns Manville products deliver consistent high quality.



717 17th St.
Denver, CO 80202
(800) 654-3103
specJM.com

North American Sales Offices, Insulation Systems

Eastern Region
P.O. Box 158
Defiance, OH 43512
(800) 334-2399
Fax: (419) 784-7866

Western Region & Canada
P.O. Box 5108
Denver, CO 80217
(800) 368-4431
Fax: (303) 978-4661

The physical and chemical properties of Permacote® Linacoustic® R-300 Rigid Fiber Glass Plenum Liner Board listed herein represent typical, average values obtained in accordance with accepted test methods and are subject to normal manufacturing variations. They are supplied as a technical service and are subject to change without notice. Numerical flame spread and smoke developed ratings are not intended to reflect hazards presented by these or any other materials under actual fire conditions. Check with the Regional Sales Office nearest you to assure current information. **All Johns Manville products are sold subject to Johns Manville's standard Terms and Conditions including Limited Warranty and Limitation of Remedy. For a copy of the Johns Manville standard Terms and Conditions, Limited Warranty and Limitation of Remedy, and information on other Johns Manville thermal insulations and systems, call (800) 654-3103.**