



PRODUCT DESCRIPTION

Insul-SHIELD is a series of semi-rigid or rigid thermal and acoustical fiber glass insulating boards for custom curtain wall applications. They are made from inorganic glass fibers bonded with a thermosetting binder. The insulating boards are typically used where framing is not present. Coated black Insul-SHIELD is available in rolls.

APPLICATIONS

- **New and Retrofit Construction** – Insul-SHIELD insulation provides thermal and acoustical insulating values for exterior curtain wall cavities, parking structures, mechanical rooms, theaters, casinos and other commercial construction applications. The insulating boards are typically used where framing is not present. (I/S 100 is often used in shaft wall applications.)

- **Custom Curtain Wall Construction** – Exterior curtain wall cavities – Insul-SHIELD is exceptionally well suited to curtain wall construction in terms of both installation and performance. When used in the exterior envelope of steel-framed buildings, it helps reduce heat loss in the winter and heat gain in the summer. The result is an attractive, efficient thermal enclosure that significantly reduces the cost of air treatment, cuts long-term energy expenses and improves life-cycle costs.

The insulation, in sizes up to 56" x 84" (1.42 m x 2.14 m), is easily installed by one person. Insul-SHIELD is available in a variety of densities, thicknesses and facings for custom curtain wall applications. It can be custom-manufactured to precise dimensions to fit specific spandrel panel designs.

- **Standard Metal Panel Construction** – Insul-SHIELD offers a variety of sizes, densities and facings for on-the-job or in-the-shop insulation of metal panel buildings such as power plants, assembly buildings, sports arenas and other commercial facilities.

In these applications, Insul-SHIELD is field-installed between an interior liner and the outer metal panel using semi-rigid boards (I/S 150, 225) that are plain or faced with a factory-applied vapor retarder. Insul-SHIELD is also available custom-cut to fit pre-insulated metal sandwich panels.

- **General Construction** – A versatile insulation, Insul-SHIELD is also an ideal thermal barrier for masonry or concrete structures such as shopping centers, banks and many other types of low-rise commercial or institutional buildings. It is also ideal for use in parking garage ceilings.

In masonry applications, semi-rigid and rigid Insul-SHIELD boards faced with an FSK vapor retarder are installed between "Z" or hat channels applied directly to the masonry surface. Normally, gypsum board and/or architectural panels are then used as interior surfaces.

- **Theaters** – With a state-of-the-art acrylic-coated surface, Insul-SHIELD Coated Black is an ideal backdrop for theater screens. The opaque surface absorbs both sound and light, eliminating concern about back-scatter into the viewing arena.

Insul-SHIELD®

Thermal and Acoustical Semi-rigid and Rigid Board and Roll Products



PERFORMANCE ADVANTAGES

- Cost-effective – lightweight, and easy to handle and fabricate so installation is fast and total applied cost is low.
- Thermally efficient – provides effective resistance to heat transfer with R-values up to R-17.4 (RSI-3.06).
- Acoustically efficient – reduces transmission of sound through roofs and walls.
- Fire-resistant and noncombustible – (see Specification Compliance).
- Moisture-resistant – vapor-retarder facings resist water vapor transmission (see Specification Compliance).
- Noncorrosive – does not accelerate corrosion of pipes, wiring or metal studs.
- Durable – unaffected by moisture, oil, grease and most acids. It will not rot, mildew or otherwise deteriorate, preventing slumping and uninsulated voids.
- Easy to handle – unlike some products that are friable, fiber glass maintains its physical integrity during handling.
- Self-supporting – because of its rigidity, Insul-SHIELD 300 and 600 can often be attached without framing.

Insul-SHIELD®

Thermal and Acoustical Semi-rigid and Rigid Board and Roll Products

Visit us at specJM.com
Or call: 1-800-654-3103

AVAILABLE FORMS

Insul-SHIELD is available unfaced or with FSK-25, PSK, black mat or coated black facing.

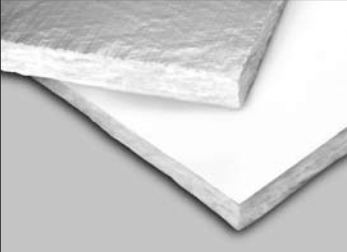
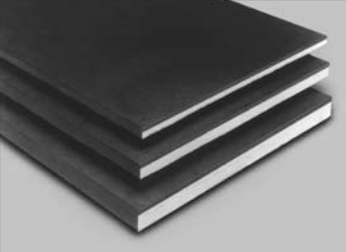
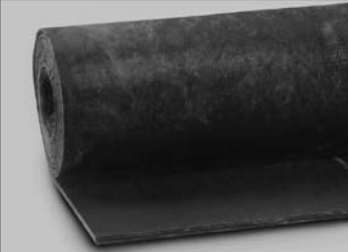
Unfaced Boards	FSK-25 or PSK-Faced Boards	Black Mat Boards	Coated Black Rolls
<ul style="list-style-type: none"> Standard board size – 24" x 48" (610 mm x 1219 mm) available for all densities. Nonstandard sizes – furnished upon request in many nonstandard lengths and widths pre-cut to meet specific dimensions. 	<ul style="list-style-type: none"> Standard board size – 24" x 48" (610 mm x 1219 mm) available for all densities. Nonstandard sizes – furnished upon request in many nonstandard lengths and widths pre-cut to meet specific dimensions. 	<ul style="list-style-type: none"> Standard board size – 24" x 48" (610 mm x 1219 mm) available for all densities. Nonstandard sizes – furnished upon request in many nonstandard lengths and widths pre-cut to meet specific dimensions. 	<ul style="list-style-type: none"> Roll form – I/S 100 and 150 available in 16", 24" and 48" (406 mm, 610 mm, and 1219 mm) widths. Available in 1" (25 mm) and 2" (51 mm) thicknesses. Available with face and edge coating where black color is specified.
			
Insul-SHIELD boards are designed for custom curtain wall applications.	Faced Insul-SHIELD boards can be used where a vapor barrier is needed. FSK facing has the best fire performance characteristics and helps maximize lighting efficiency.	Insul-SHIELD Black provides a semi-rigid substrate beneath the fabric treatment used on theater side walls. The black, mat-faced insulation provides adequate shadowing behind any surface treatment.	Insul-SHIELD Coated Black is ideal for theater applications. Product shown was specified with both face and edge coating.

INSTALLATION

Insul-SHIELD can be easily cut and friction-fit between vertical or Z-shaped framing or hat channels applied directly to a masonry surface. The insulation can also be installed with impaling pins or with suitable adhesives.

In standard metal panel construction applications, Insul-SHIELD is field-installed between an interior liner and the outer metal panel. Normally, gypsum board and/or architectural panels are then used as interior surfaces. Some trimming may be necessary if used in ceiling grids, as this product is a commercial-use board.

Note: In colder climate areas, vapor retarders (whether attached to the insulation or applied separately) are often placed toward the heated or conditioned side of the wall. This is done to reduce water vapor penetration into the wall from the building interior. Conversely, in predominantly hot, humid climates local practices often call for placing the vapor retarder toward the outside of the wall cavity. Check your local building codes for vapor retarder requirements.

Recommended Pin Patterns

I/S 100, 150, 225, 300 and 600: pins should be placed approximately 3"–5" (76 mm–127 mm) from the edges of the product.

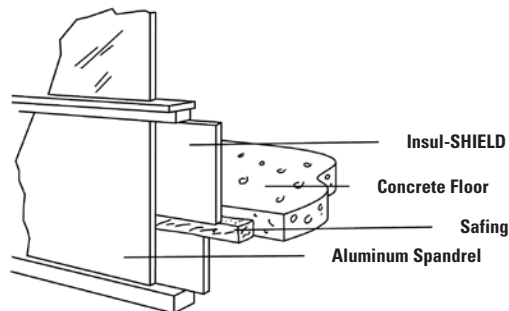
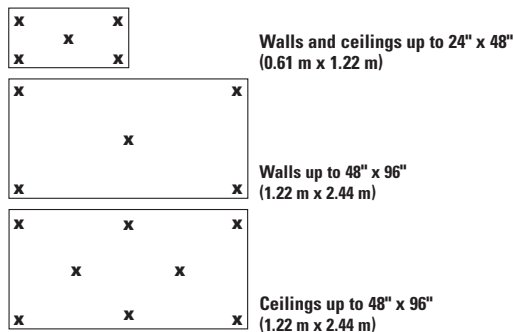

Insul-SHIELD®

Thermal and Acoustical Semi-rigid and Rigid Board and Roll Products

Visit us at specJM.com
Or call: 1-800-654-3103

STANDARD DIMENSIONAL DATA AND FACINGS*

Type	"k"- Values Btu·in/(hr·ft ² ·°F)	(w/m·°K)	Thickness (in)	Thickness (mm)	Facing**
I/S 100	0.27	0.039	1½	38	Unfaced
I/S 150	0.24	0.035	1, 1½, 2, 2½, 3, 3½, 4	25, 38, 51, 64, 76, 89, 102	Unfaced, FSK-25, PSK
I/S 225	0.23	0.033	1, 1½, 2, 2½, 3, 3½, 4	25, 38, 51, 64, 76, 89, 102	Unfaced, FSK-25, PSK
I/S 300	0.23	0.033	1, 1½, 2, 2½, 3, 3½, 4	25, 38, 51, 64, 76, 89, 102	Unfaced, FSK-25, PSK
I/S 600	0.22	0.032	1, 1½, 2, 2½, 3	25, 38, 51, 64, 76	Unfaced, FSK-25, PSK
I/S Coated Black	0.25	0.036	1, 2	25, 51	Durable black-coated surface

* Product sizes vary by plant locations; consult your Johns Manville sales representative for other available sizes.

** Meets HH-B-100 B, Type I and II specifications.

SOUND ABSORPTION DATA*

1" (25 mm) Thickness Unfaced (Type "A" Mounting)**

Type	Density		Typical Coefficients by Frequency (Hz)							Thermal Data	
	pcf	kg/m ³	125	250	500	1000	2000	4000	NRC***	"R" (hr·ft ² ·°F)/Btu	"RSI" m ² ·°K/w
I/S 150	1.5	24.0	0.07	0.24	0.63	0.87	1.00	1.02	0.70	4.2	0.74
I/S 225	2.25	36.1	0.08	0.27	0.69	0.95	1.05	1.02	0.75	4.3	0.76
I/S 300	3.0	48.1	0.06	0.29	0.75	0.99	1.04	1.02	0.75	4.3	0.76
I/S 600	6.0	96.1	0.10	0.35	0.85	1.04	1.05	1.03	0.80	4.5	0.79

1½" (38 mm) Thickness Unfaced (Type "A" Mounting)**

Type	Density		Typical Coefficients by Frequency (Hz)							Thermal Data	
	pcf	kg/m ³	125	250	500	1000	2000	4000	NRC***	"R" (hr·ft ² ·°F)/Btu	"RSI" m ² ·°K/w
I/S 100	1.0	16.0	0.15	0.37	0.81	0.96	1.04	1.01	0.80	5.6	0.99
I/S 300	3.0	48.1	0.13	0.62	1.07	1.08	1.06	1.04	0.95	6.5	1.14
I/S 600	6.0	96.1	0.14	0.60	1.01	1.08	1.06	1.05	0.95	6.8	1.20

2" (51 mm) Thickness Unfaced (Type "A" Mounting)**

Type	Density		Typical Coefficients by Frequency (Hz)							Thermal Data	
	pcf	kg/m ³	125	250	500	1000	2000	4000	NRC***	"R" (hr·ft ² ·°F)/Btu	"RSI" m ² ·°K/w
I/S 150	1.5	24.0	0.24	0.68	1.10	1.13	1.10	1.07	1.00	8.3	1.46
I/S 225	2.25	36.1	0.19	0.88	1.15	1.14	1.10	1.07	1.05	8.7	1.53
I/S 300	3.0	48.1	0.24	1.00	1.11	1.08	1.06	1.05	1.05	8.7	1.53
I/S 600	6.0	96.1	0.38	0.93	1.10	1.07	1.07	1.07	1.05	9.1	1.60

2" (51 mm) Thickness FSK-25/PSK Faced (Type "A" Mounting)**

Type	Density		Typical Coefficients by Frequency (Hz)							Thermal Data	
	pcf	kg/m ³	125	250	500	1000	2000	4000	NRC***	"R" (hr·ft ² ·°F)/Btu	"RSI" m ² ·°K/w
I/S 150	1.5	24.0	0.25	1.09	1.11	0.58	0.26	0.12	0.75	8.3	1.46
I/S 225	2.25	36.1	0.32	1.17	1.00	0.75	0.42	0.20	0.85	8.7	1.53
I/S 300	3.0	48.1	0.41	1.13	0.85	0.73	0.38	0.16	0.75	8.7	1.53
I/S 600	6.0	96.1	0.49	0.26	0.68	0.47	0.33	0.22	0.45	9.1	1.60

I/S Coated Black; 1.5 pcf (24.0 kg/m³) Density (Type "A" Mounting)**

Thickness (in)	Thickness (mm)	Typical Coefficients by Frequency (Hz)							Thermal Data	
		125	250	500	1000	2000	4000	NRC***	"R" (hr·ft ² ·°F)/Btu	"RSI" m ² ·°K/w
1	25	0.09	0.29	0.67	0.89	1.03	0.99	0.70	4.0	0.70
2	51	0.23	0.73	1.05	1.13	1.06	1.07	1.00	8.0	1.41

* Per ASTM C 423.

** Type "A" Mounting per ASTM E 795.

*** Noise Reduction Coefficient.

RECOMMENDED STORAGE AND TRANSPORT

Store insulation indoors. Keep insulation clean and dry at all times. When transporting, cover completely with a waterproof tarpaulin as necessary.

SPECIFICATION COMPLIANCE*

Insul-SHIELD complies with applicable ASTM and federal specifications and the standards of ICBO, BOCA and SBCCI building codes. It meets air erosion standards up to 1,800 fpm (9.14 m/s) per UL 181.

Type	I/S 100	I/S 150	I/S 225	I/S 300	I/S 600	Coated I/S Black
ASTM C 612, Type IA, Category 1**	X	X	X	X	X	X
ASTM C 612, Type IB, Category 1**		X	X	X	X	
ASTM C 612, Type IB, Category 2**				X	X	
ASTM C 553, Type I and II**	X	X				
ASTM C 665, Type I**	X	X				
ASTM C 665, Type III,** Class A, Category 1 or 2		X				
ASTM E 136 (Noncombustible)	X	X	X	X		
ASTM E 84 (Flame/Smoke 25/50 or less)	X	X	X	X	X	X

* When ordering material to comply with any government specification (or any other listed specification), a statement of that fact must appear on the purchase order.
** Exceptions to ASTM standards: Not tested for compression resistance. Not tested for use at elevated temperatures. Corrosiveness is tested in galvanized steel instead of plain low-carbon steel. Type 100 has k value of 0.27 Btu-in./hr.-sq. ft.-F) at 75° F mean temperature.

SHORT FORM SPECIFICATION

All insulation shown on drawings or specified herein shall be “Johns Manville Insul-SHIELD Thermal and Acoustical Insulation.” Thermal resistance “R” (RSI) values of the insulation shall be R (RSI) _____ in ceilings, R (RSI) _____ in walls, and R (RSI) _____ in floors over unheated spaces. The product shall have an FHC rating of 25/50 or less.

LIMITATIONS OF USE

Check applicable building codes.

Properly insulating a structure using Johns Manville building insulation helps preserve our environment by reducing energy consumption for heating and cooling, reducing the pollution resulting from fuel burning, reducing the emission of hazardous air pollutants during manufacturing and reducing waste through the utilization of recycled materials.

Technical specifications as shown in this literature are intended to be used as general guidelines only. The physical and chemical properties of Insul-SHIELD thermal and acoustical fiber glass insulation listed herein represent typical, average values obtained in accordance with accepted test methods and are subject to normal manufacturing variations. They are supplied as a technical service and are subject to change without notice. Any references to numerical flame spread or smoke developed ratings are not intended to reflect hazards presented by these or any other materials under actual fire conditions. Check with the sales office nearest you for current information. All Johns Manville products are sold subject to Johns Manville’s Limited Warranty and Limitation of Remedy. For a copy of the Johns Manville Limited Warranty and Limitation of Remedy or for information on other Johns Manville thermal and acoustical insulation and systems, call or write to the 800 number or address listed below.



Distributed by:

Building Insulation Division

717 17th Street (80202)
P.O. Box 5108
Denver, CO 80217-5108
1-800-654-3103
JM.com