

CUT LINES (TYP.)

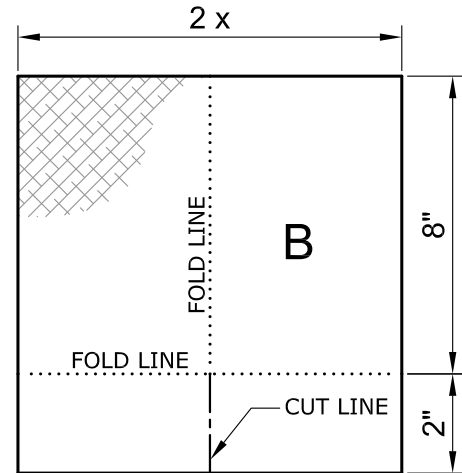

VERTICAL SURFACES
STEPS A & B

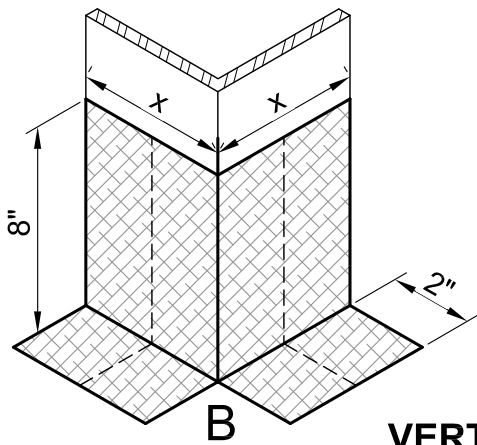
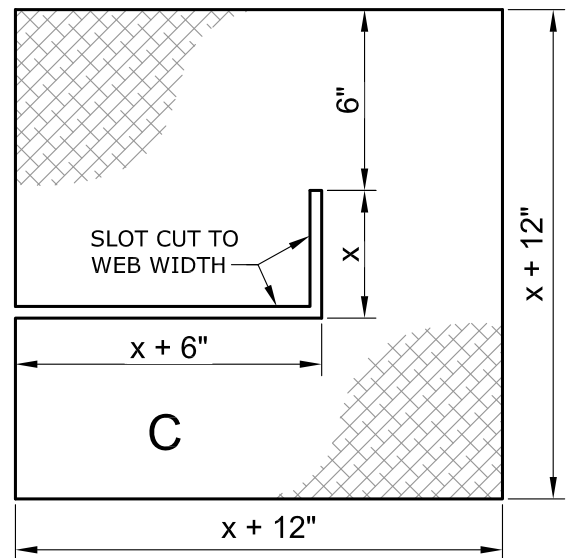
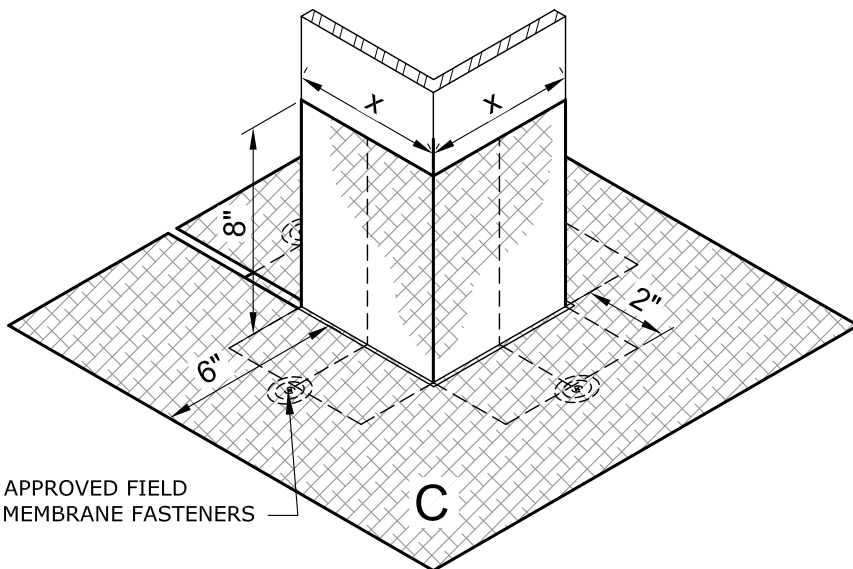

HORIZONTAL SURFACE
STEP C

NOTES:

1. ALL FOLD LINES REPRESENTED AS
ALL CUT LINES REPRESENTED AS - - - -

USE THIS DETAIL IN CONJUNCTION WITH DETAILS SPL-FP-08/09 WHICH IS PART OF THIS INSTALLATION.

DRAWING NO.

SPL-FP-10

ANGLE IRON FLASHING SCRIM LAYOUT

MEMBRANE TYPE:
JM SP LIQUID

SCALE
N.T.S

ISSUE DATE
04-17-20

MAXIMUM GUARANTEE TERM:
N/A

Johns Manville is a manufacturer of commercial roofing products and offers this general conceptual information to you as a courtesy. This complimentary assistance is not to be used or relied upon by anyone as a substitute for professional engineering design and documentation required by building code, contract, or applicable law. By accepting these comments you agree they do not constitute any representations, endorsements of, or an assumption by Johns Manville of any liability for either the adequacy of the design of this building or any other material not supplied by Johns Manville.

