

A WALL REINFORCEMENT
STEP A

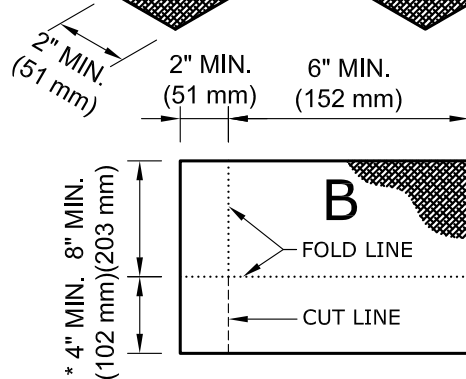
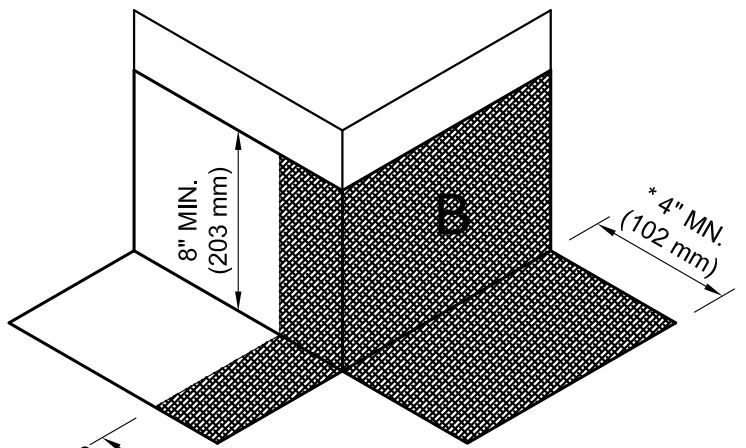

B WALL TRANSITION
STEP B

USE THIS SCRIM LAYOUT IN CONJUNCTION WITH
DETAIL LB-FC-04I WHICH IS PART OF THIS INSTALLATION

ALL FOLD LINES REPRESENTED AS
ALL CUT LINES REPRESENTED AS -----
*ADD 3 1/2" IF DETAIL UTILIZES CANT STRIP

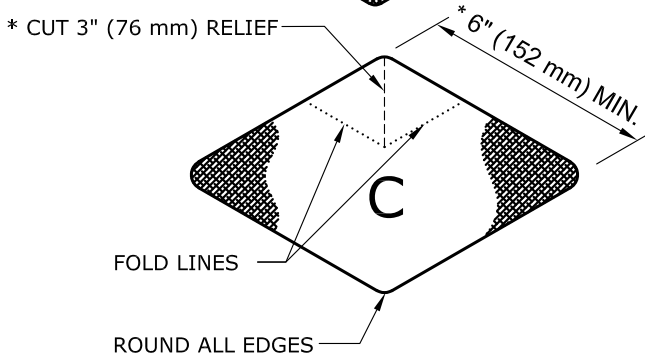
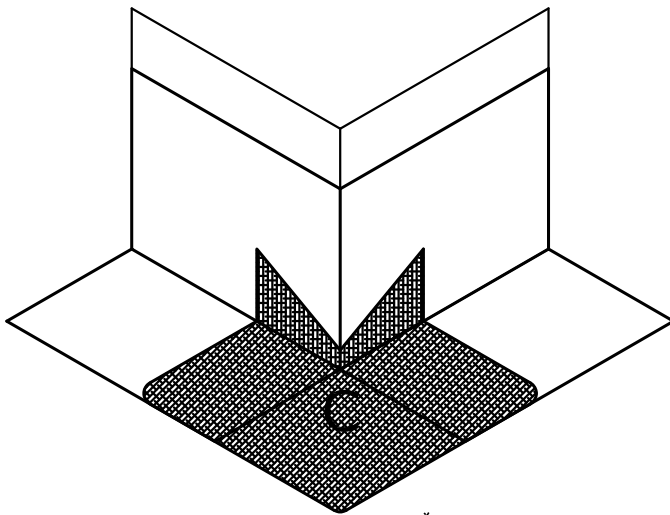

C CORNER REINFORCEMENT
STEP C

NOTES:

1. REFER TO JOHNS MANVILLE WEBSITE (www.jm.com) FOR MOST UP-TO-DATE INFORMATION.
2. PLEASE SEE JM PMMA FLASHING SPECIFICATIONS FOR A FULL DESCRIPTION OF INSTALLATION INSTRUCTIONS AND REQUIREMENTS WHICH ARE CONSIDERED A PART OF THIS DETAIL.
3. ANY CARPENTRY OR METAL WORK SHOULD BE DESIGNED AND CONSTRUCTED IN ACCORDANCE WITH LOCAL CODE REQUIREMENTS AND/OR PROJECT SPECIFICATIONS. THESE COMPONENTS SHOULD BE REVIEWED AND APPROVED BY A LICENSED DESIGN PROFESSIONAL.
4. JM PMMA MEMBRANE FLASHING CONSISTS OF JM PMMA STANDARD RESIN, JM PMMA SCRIM, JM PMMA STANDARD RESIN. USE THE APPROPRIATE JM PMMA PRIMER DEPENDING ON TYPE OF SUBSTRATE.

DRAWING NO.

LB-FC-04S

NEW DETAIL

SCALE

N.T.S

ISSUE DATE

6-18-18

MEMBRANE TYPE:
JM PMMA OVER BITUMINOUS

MAXIMUM GUARANTEE TERM:

20 YEAR

TYPICAL OUTSIDE CORNER SCRIM LAYOUT

Johns Manville is a manufacturer of commercial roofing products and offers this general conceptual information to you as a courtesy. This complimentary assistance is not to be used or relied upon by anyone as a substitute for professional engineering design and documentation required by building code, contract, or applicable law. By accepting these comments you agree they do not constitute any representations, endorsements of, or an assumption by Johns Manville of any liability for either the adequacy of the design of this building or any other material not supplied by Johns Manville.

